

Tailgate Lifter

Swing type

GVW3~8 t



S600

■ Features

■ Platform movement

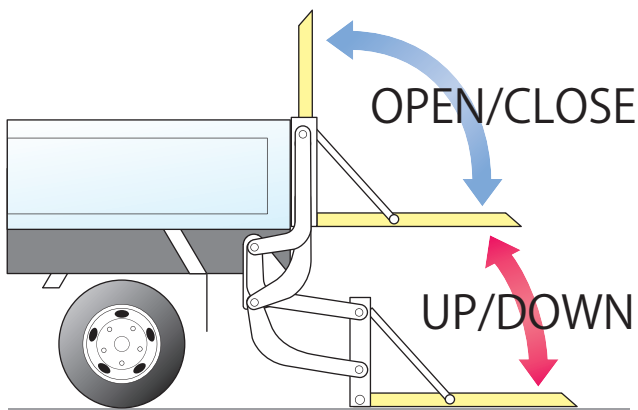

■ Brake valve enables to slow down the lifting speed when near the body deck.

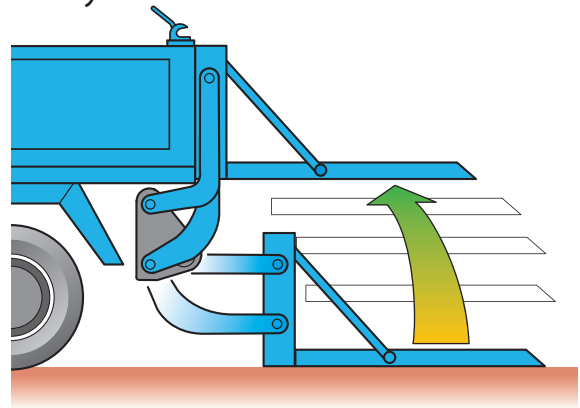

The vehicle in the photographs include optional equipments, special coloring and processing.

Tailgate Lifter Swing type

■ Standard equipments

● Power unit

Low noise power unit and controller are accommodated in a highly durable stainless box.



● 3m cable remote controller

Operation can be done while checking condition of cargo on a platform.



■ Specifications

Model	S600	S800	S1000
Max lifting capacity (kg)	600	800	1,000
Max body deck ground height (mm)	700~1,150	750~1,200	
Platform dimensions	Length (mm)	850	
	Width (mm)	1,490~2,260	
Lifting time (sec.)	4~18		
Lowering time (sec.)	4~18		

The above mentioned figures are approximate.

■ Structure diagram

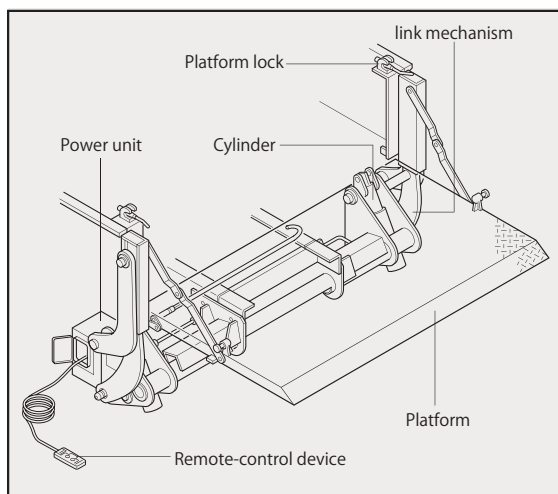

Note: Specifications and the other contents on this catalogue are subject to change without prior notice due to product improvement.
Product photos on this catalogue might include optional devices.

Kyokuto Kaihatsu Kogyo Co., Ltd.

TOKYO OFFICE
3-15-10 ,Higashi-shinagawa, Shinagawa-ku, Tokyo, 140-0002, Japan
Telephone : +81(3)5781-9828 Facsimile : +81(3)5781-3438
E-mail : web-overseas@kyokuto.com
<http://www.kyokuto.com/>