

# Tailgate Lifter

## Vertical type

GVW3~20t



V600

### ■ Features

Vertical movement of tail gate suits well for carrying tall or wobbly Loads.

#### ■ Platform movement

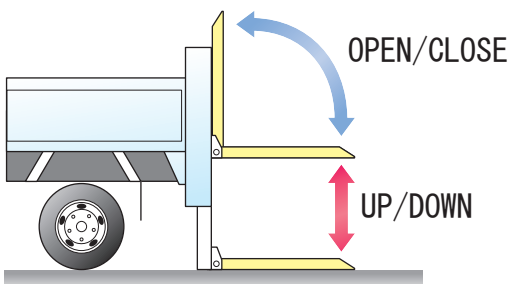

#### ■ For gas cylinder

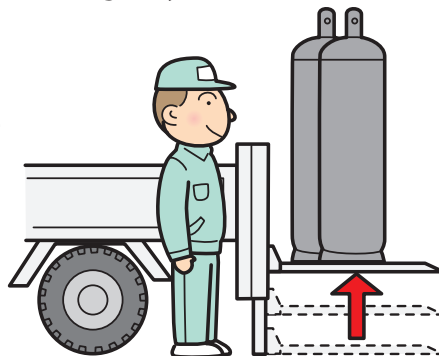

#### ■ For plants

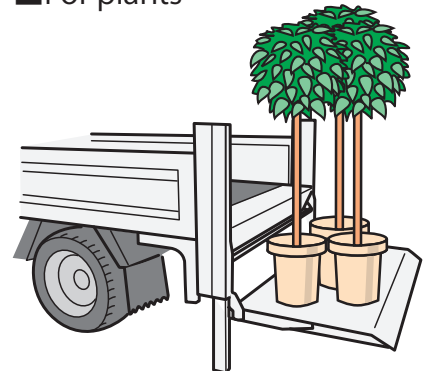

The vehicle in the photographs include optional equipments, special coloring and processing.

# Tailgate Lifter Vertical type

## Standard equipments

### Originally developed power unit

Product reliability has been improved by putting our originally developed power unit in a cross member.

※Only V600・800



### Operation switch

「UP」 and 「down」 operations can be done by push buttons.

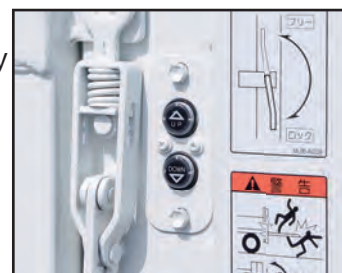

## Specifications

Model		V300	V600	V800	V1000
Max lifting capacity	(kg)	300	600	800	1,000
Max body deck ground height	(mm)	690~900	750~1,160	750~1,200	1,000~1,520
Platform dimensions	Length	650	850	1,000	
	Width	1,490~1,570	1,570~2,340	1,570~2,340	2,050~2,350
Lifting time	(sec.)	5~15			
Lowering time	(sec.)	5~15			

The above mentioned figures are approximate.

## Structure diagram

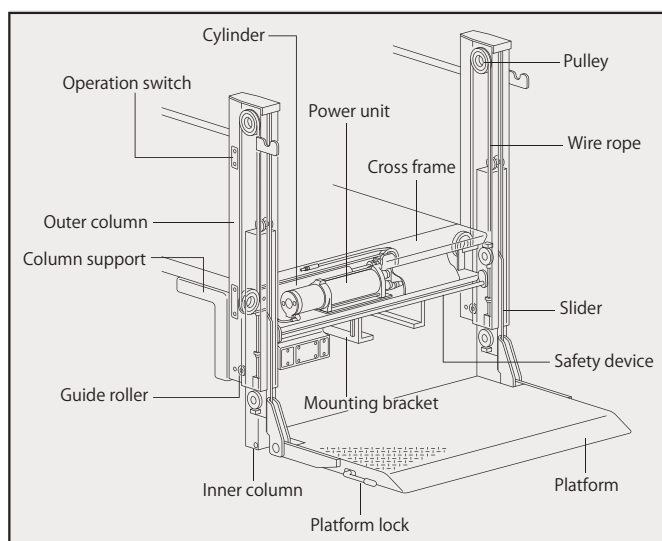

Note : Specifications and the other contents on this catalogue are subject to change without prior notice due to product improvement.  
Product photos on this catalogue might include optional devices.

## Kyokuto Kaihatsu Kogyo Co.,Ltd.

TOKYO OFFICE

3-15-10 ,Higashi-shinagawa, Shinagawa-ku, Tokyo, 140-0002, Japan

Telephone : +81(3)5781-9828 Facsimile : +81(3)5781-3438

E-mail : web-overseas@kyokuto.com

http://www.kyokuto.com/